

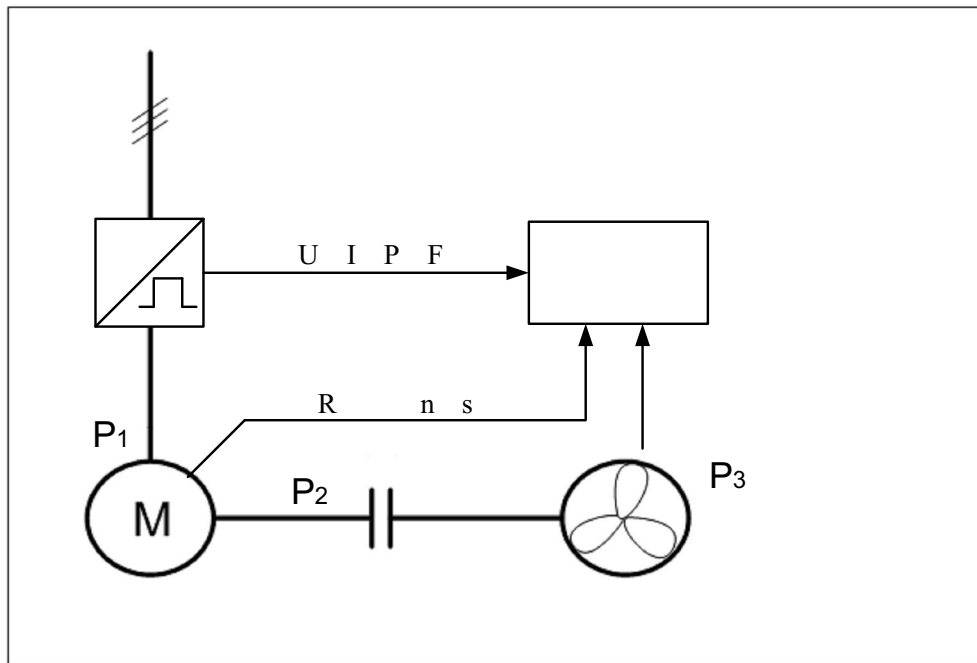

# 一种免扭矩仪的电动机轴功率实时测量方法





$$P_2 = P_1 - P_{Fe} - P_{fw} - P_{cu1} - P_{cu2} - P_s$$

$$\eta = \frac{P_2}{P_1}$$

$$P_{\text{con}} = P_{\text{Fe}} + P_{\text{fw}} = P_0 - 1.5I_0^2 R_0$$

$$P_{\text{cu1}} = 1.5I_1^2 R_t$$

$$R_t = R_c \frac{K_1 + \theta_t}{K_1 + \theta_c}$$

$$P_{\text{cu2}} = (P_1 - P_{\text{cu1}} - P_{\text{Fe}})S$$

5.



---

1

2

GB/T 1032-2012